

User's Manual

SMR-600 Needle Detector (Conveyor-Type)

For Information

TEL: 00-82-51-526-3410

Fax: 00-82-51-526-3610



<http://www.smr2000.com>

ISO 9001 (2000) & KSA 9001 (2001) Authentication Obtained

Please be sure to read before use for proper use and safety

TABLE OF CONTENTS

1. Safety precautions
2. Definition of operator and qualified technician
3. Safety warning
4. Product description
5. Product specifications
6. Power supply
7. Transportation and installation
 - 7.1) Transportation
 - 1) Handling wooden pack
 - 2) Transporting the machine to the place
 - 7.2) Suggestions for choosing the installation site
8. Name of parts
 - 1) Body
 - 2) Operation panel
 - 3) Testing box
9. Setting the machine before operation
10. How to operate
11. Trouble shooting
12. Maintenance
13. Repair
14. Quality grantee

1. Safety Precautions

Caution: The followings are directly related to the user's safety and should be kept in mind when using the product. Our obligations under the guarantee presuppose as the following conditions.

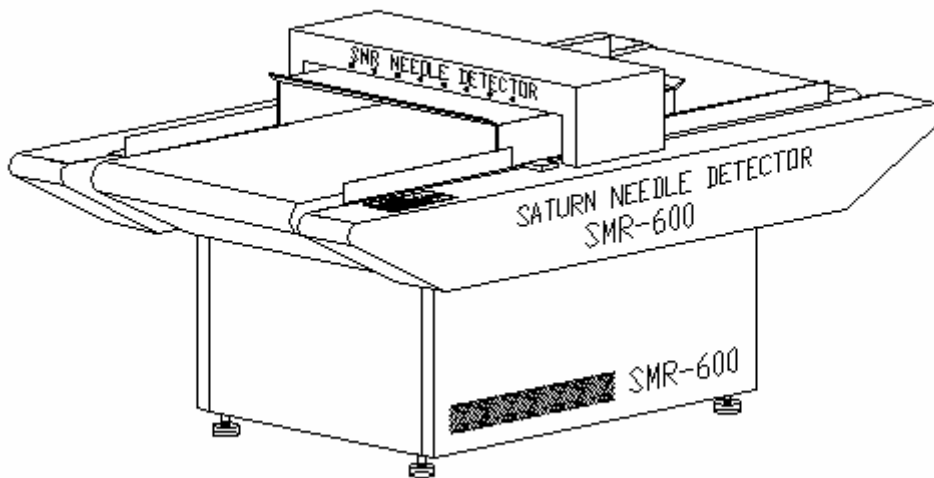

1) The user is obliged to assign the work to only qualified person who have been properly instructed and well trained.

2) A person who use a pace maker because of a cardiac disorder do not come close to the machine.

This machine include strong magnets so that this magnet can trouble on the operating of the pace maker.

3) Do not put your hands in the belt when it is in operation.

4) Do not clean the conveyor belt or other parts of the machine when the power is on.

5) Do not open the cover of the electronic circuit control box. Doing so while the power is on may lead to electrocution by the electric circuit within.

6) Pull the plug out.

When the machine is not in use or needs to be checked, it is safe to shut off the power supply.

7) Always monitor the machine when it is operating.

When using the machine, always monitor the work process, and have a personnel keep an eye on whether the machine functions normally or not at all times.

8) Do not disassemble, remodel, or repair without our company's agreement.

When repair is needed, always contact our company. We take no responsibility for the accidents and casualties due to the repairs or disassembly of the machine that is not done by our personnel.

9) Always keep the workplace and its surroundings in order.

Disorder in the workplace may cause unexpected accidents.

10) Possession of any magnetic or metallic materials is prohibited when operating the machine.

If the operator of the machine has magnetic substances (magnets) or materials which contain iron(Fe), the machine will malfunction and proper inspection will be disabled.

11) Possession of any types of card is prohibited when operating the machine.

Because this product uses strong magnets, having cards in possession while working near the product may do damage to the cards.

2. Definition of operator and qualified technician

1)operator

It doesn't require to use high skilled person or person who has any

special technical knowledge.

Anyone who are well trained from the operating lines can operate this machine.

2) Qualified technician

Technician means a person who is assigned on more complex installations, maintenances and repairs and other specialized works.

Make sure that the assigned person doesn't perform any other works which are beyond their fields of knowledge and responsibilities.

The qualified technician is defined in accordance with level of the following listed conditions.

a) training, experiences and education

b) knowledge for regulations, rules and prevention manner of accidents

c) knowledge of the service conditions of the machinery and has been assigned by safety manager of the plant.

And the person who can operate high-voltage electrical system and knows any special regulations on the operation of high-voltage electrical systems.

3. Safety warnings

1) warning label contains all the important information and locates on the part of the machine where everybody can see with easy.

This warning label contains critical information that is strictly observed by operators. In case anybody failure to observe this critical information it might happen any serious accidents.

2) Warning label are marked as danger, warning and caution depends on the level of seriousness of the hazards.

Danger : imminently hazardous situations – failure to observe the instructions might cause serious injuries or death.

Warning : potentially hazardous situations – failure to observe the instructions might cause serious injuries or death

Caution : potentially hazardous situations – failure to observe the instructions might cause minor injuries and damages on the machine.

3) The warning label has always to be in very clean condition so that operators can read easily. In case the warning label is not in clean condition, it has to be cleaned immediately.

4) Never remove the caution labels, in case the caution label comes off, it has to be re-affixed at the original position.

5) Never put anything on the caution label and paint over it.

6) If any part of the caution label in blurriness condition, it has to be replaced.

7) In addition to the information shown on the caution label, there are varieties of cautionary information that have to be observed by operators during the machine installations, operation and maintenance works.

This cautionary information is being mentioned on this instruction manual.

Read all the information carefully.

If anybody neglect to observe the warning operators and anybody who are in near by with the machine and any damages on the machine.

This information has to be always observed during the machine installations, operations and maintenance works.

8) The location of warning labels.

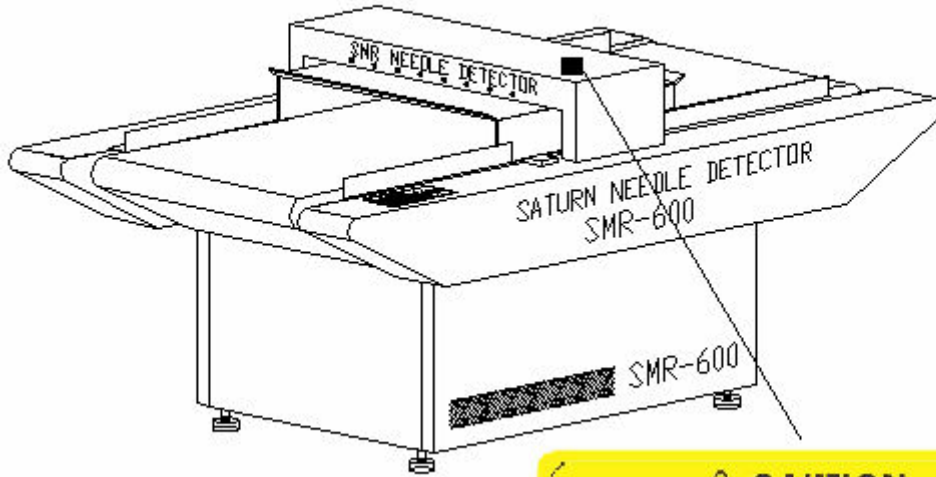

 **WARNING**

Read contents of safety warning labels carefully and keep them in mind.

Do not peel off or rub safety warning labels.

Confirm locations of safety warning labels.

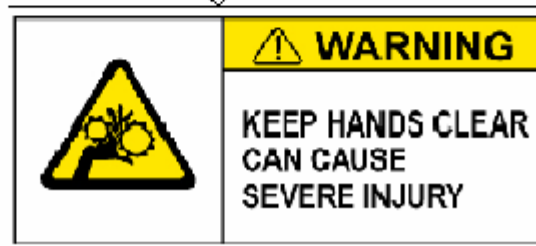
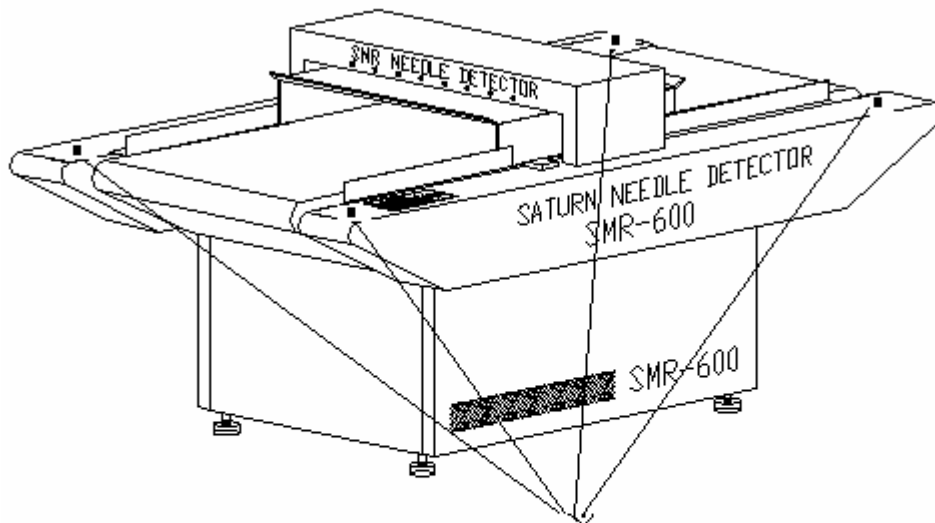

WARNING

Do not put your hands around warning label when this machine is in the operation.

Your hands can be caught in a conveyor belt or connecting parts so that you can have severe injury.

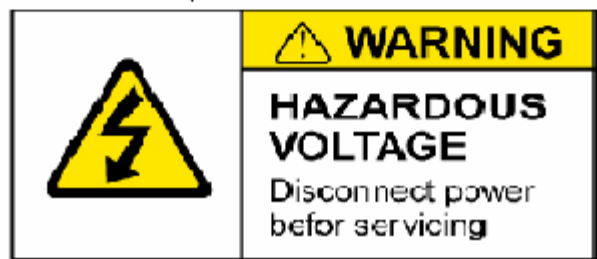
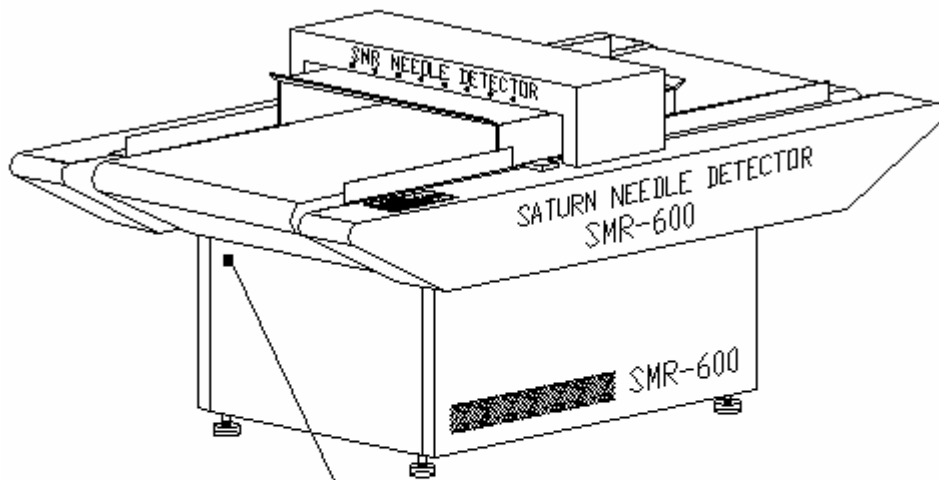

 **WARNING**

Electronic panel is located in this side.
Do not operate this machine when a door is opened.
Otherwise, it can cause serious electronic shock.

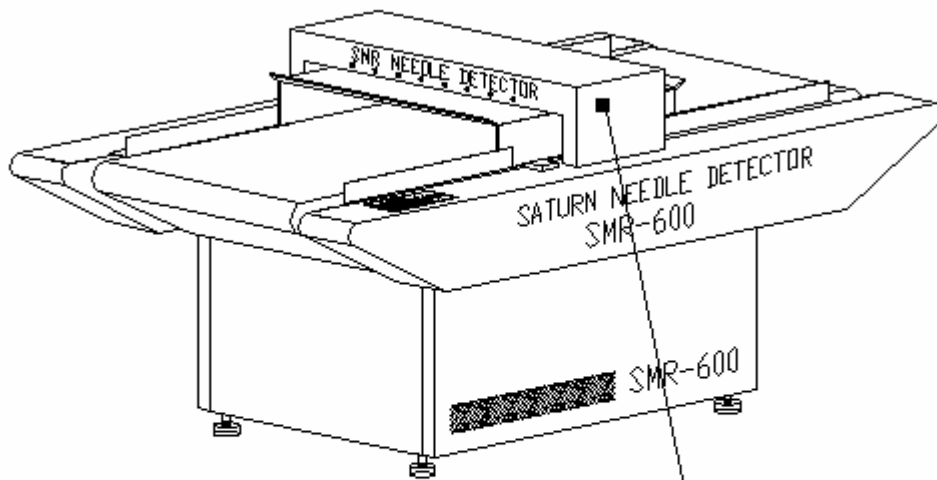

WARNING

Strong magnet is located.

A person who use a pace maker because of a cardiac disorder do not come close to the machine.

This machine include strong magnets so that this magnet can trouble on the operating of the pace maker.

4. Product description

The needle detector of SMR is a high-tech equipment that detects

broken needles and fragments of iron (Fe) contained in all needle works and indicates their locations by part. Then the machine stops working or returns to the input position.

Although needle detectors that utilize magnets do not normally detect non-ferric metals, such as copper, copper alloy, gold, silver, and aluminum, they may respond to them if their size is large enough, especially if they contain fractions of iron.

Consequently, although most zippers and buttons used for needleworks are non-ferric, please use specially gilded ones if iron is contained in them.

5. Product specifications

Model	SMR-600A	SMR-600B	SMR-600C
Detective Capability (Fe)	1.0mm	1.5mm	2.0mm
Weight	200kg	210kg	220kg
Detective Height	100mm	150mm	200mm
Conveyor Length	1560mm		
Detective Width	600mm		
Belt Speed	30m / min		
List of Electricity	AC 220V, 2P, 50 / 60Hz		
Power	60W/h		
Control of Capability	10 steps		
Alarm	Electronic Buzzer, Lamp, Returning of Detection to Start Position		

6. Power Supply

The power supply is set at AC 220V 50/60Hz in a single phase mode at the time of shipping. When wishing to use an alternative power supply, please consult our sales agency or our company first.

7. Transportation and installation

7.1) Transportation

1) Handling wooden pack

- The machine is packed in a wooden crate.
- The gross weight is about 200kg so you must use a folk lift to transport this wooden pack.
- The over all dimensions and weight of the packaging are to be indicated.
- In consideration of the length of crate, insert the folks of the folk lift or suitable lifting facility in the center position.
- The folks have to be protruded from one side of crate to ensure that the other side is from any obstacles.
- Lift the crate carefully and transport it to the place where it will be opened.
- Remove the side and top side of crate.
- Release the machine from the bottom side of crate.

2) Transporting the machine to the place of installation

-If there is a raised spot or a door sill, please use the folk lift to transport the machine.

If using a folk lift to move the machine, observe the following procedures.

Locate the folk lift at the front of machine and slide the folk under the bottom of the machine to hold up the machine and lift the machine carefully. It is very important to keep the balance of the machine. The holding capacity of the folk lift has to be good enough to lift the machine.

-In the flat place, two persons can transport the machine by using wheels under the machine.

After completion of installation the machine, down footholds until wheels don't reach the place.

7.2) Suggestions for choosing the installation site

Caution: Before installing the needle detector, please read the following suggestions carefully. Proper installation may have crucial effects on the efficiency of the product.

1) Install the product at a place with little external tremor, and keep it fixed at level by using footholds so that the needle detector may not shake due to the internal vibration.

2) Put the product at a place with constant temperature and low moisture.

3) Do not install the product at places where strong electric sparks occur, e.g., near grinders or high-capacity motors.

4) Do not install the product near shaking metals, e.g., highly vibrating machines or moving cars.

5) Install at a place with consistent power supply (in voltage and current).

Do not share power supply with machines that consume a massive amount of electricity (high-capacity air conditioner or motors, for example). Doing so will cause large fluctuations in electrical voltage.

6) Install the needle detector away from machines emitting a huge amount of electronic or magnetic waves (sewing machine with automatic thread trimmer, cleaning gun, vacuum board, for

example).

7) Do not install the product in or around buildings with high-frequency equipments (vinyl adhesive machines, for instance). Do not share the same power supply with them.

8. Name of Parts

1) Body of needle detector

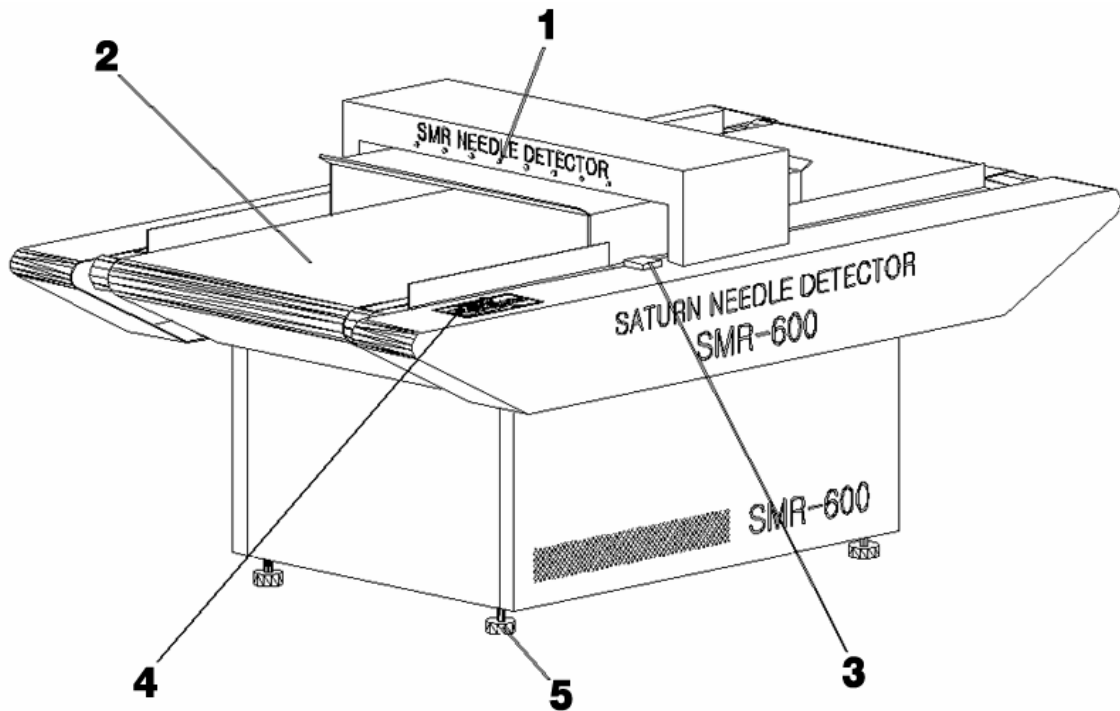

1. **Lamp of each part** : this lamp is lighted when a needle is detected.
2. **Conveyor belt** : conveyor belt have a role to convey products.
3. **Sensor** : this sensor sense whether a product pass in a detecting tunnel and give a signal to start detecting.
4. **Operation Panel**
5. **Footholds for setting of height** : You can adjust the height of this machine by using this footholds

2) Operation panel

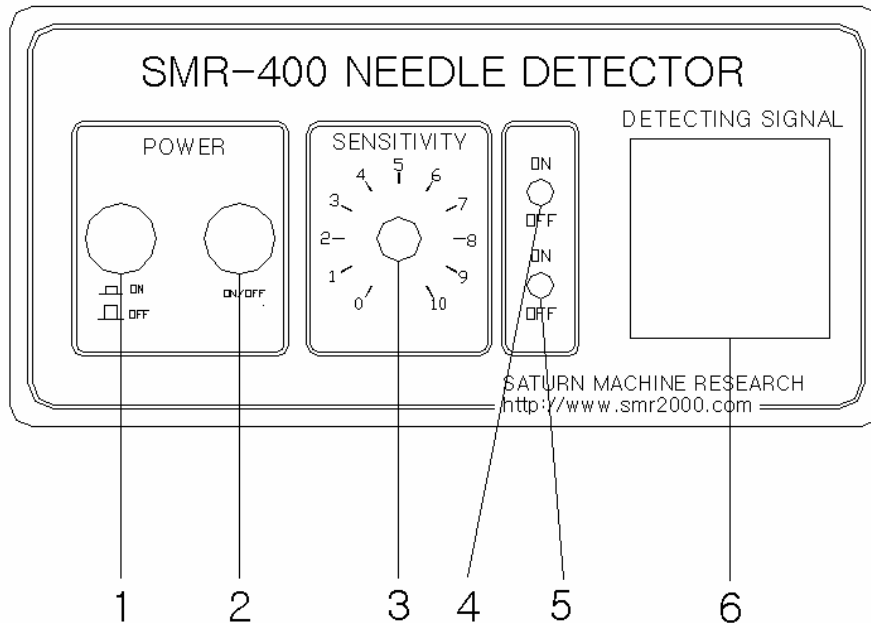

1. Power Switch

2. Switch for Operating the Conveyor Belt

Start to operation after this operating switch be turned on.

3. Adjustment Switch for the Volume of Detection Sensitivity

4. Detected Materials Return Switch

When this switch is turned on, a signaling sound is heard if ferric materials are detected and the materials are returned to the site where they were inputted into the detector. When the switch is turned off, the detector goes into the test mode. In this mode, the detection lamp is lit red without the signaling sound, and the detected materials are not returned to the site of input.

Turn the switch on for general use.

5. Test mode Switch

When this switch is turned on, the detector is in the general mode. **You must turn on this switch for general using.**

When the switch is turned off, the detector is in the test mode. In this mode, the conveyor belt continually returns and restarts whether it detect or not so that repetitive detection tests are possible. In case the detection lamp is lit red without the signaling sound so you can confirm the detection only by the lamp.

6. Quantity Counter

This counts the number of products that pass the detection test successfully.

3) Testing Box

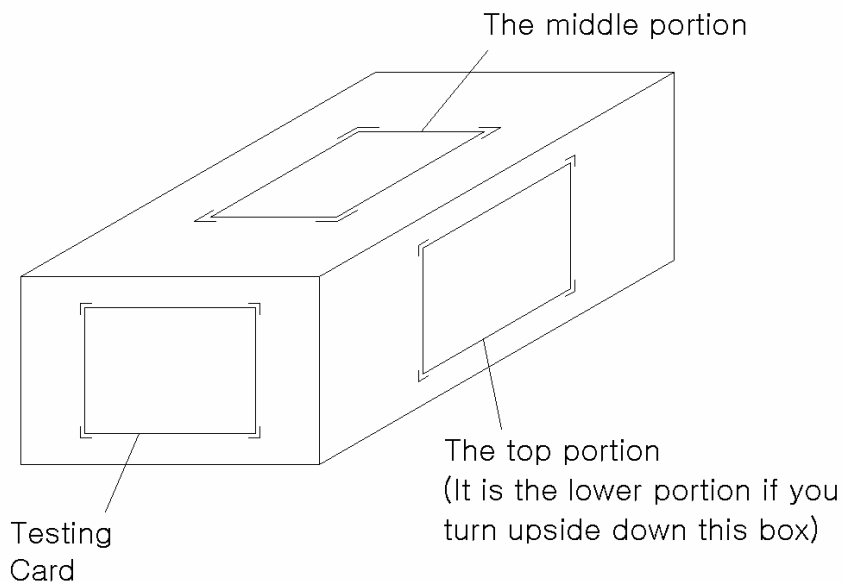

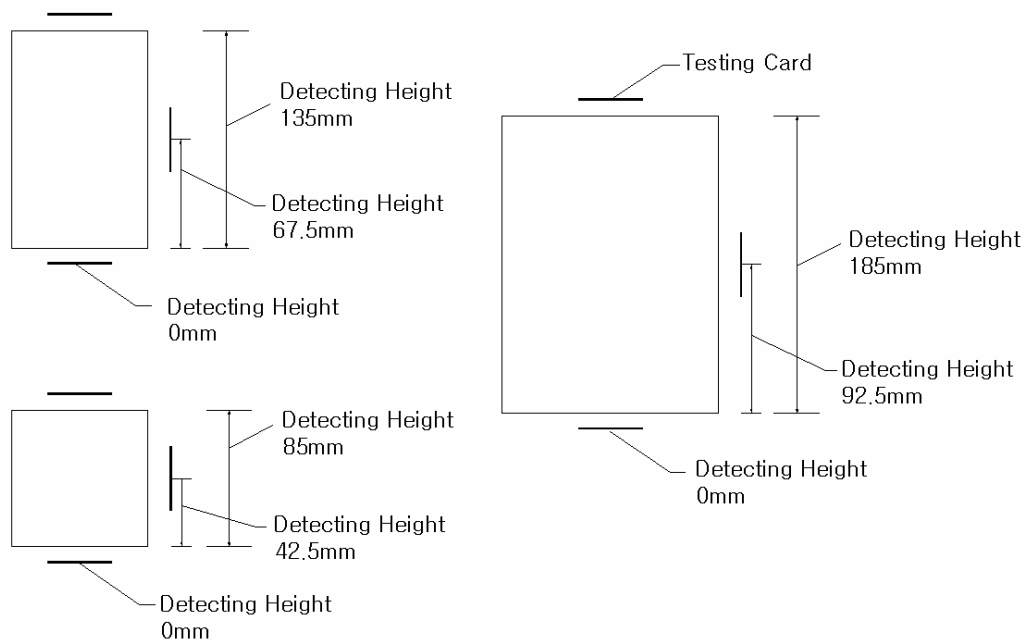

9. Setting the Machine Before Operation

-The way of adjusting the degree of detection sensitivity

The degree of detection sensitivity must be set differently in accordance with the place of use.

- 1) In the case of needleworks without metallic accessories



First, set the adjustment volume of detection sensitivity at 10, which is the maximum.



Press the switch to operate the conveyor belt without any metallic materials.

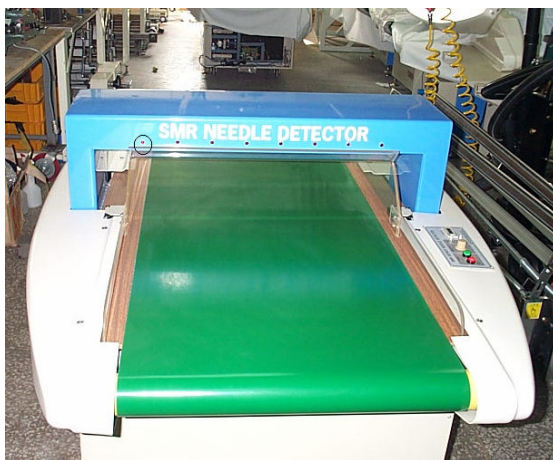

If the detection lamp is lighted red, it means that the sensitivity level is too high.

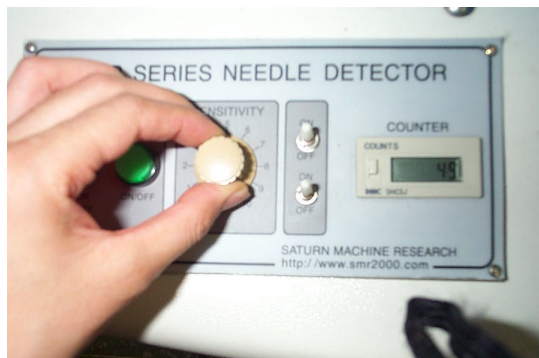

Gradually decrease the volume of detection sensitivity until the detection lamp is no longer lighted. Do not decrease the volume of the detection sensitivity under 3.

The reason the detection lamp lights up without any metallic materials is that internal vibrations generated by the operation of the conveyor belt or external tremors cause the detector to malfunction. The light-up of the lamp, therefore, means that it is necessary to lower the detection sensitivity to the point that the detection process is not affected by internal or external vibrations.

Next, detection sensitivity needs to be adjusted properly by using the test box.



Insert the test card into the test box and execute the detection test. The test box can be tested on its top, side, and bottom face.



First insert the test card at the height close to the maximum test height, place the box so that the inserted card will be on the top

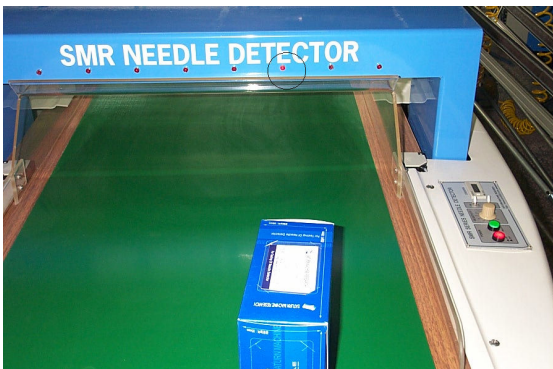

Move the box slowly from left to right to test if the detection process is carried out normally on the whole face of the box.



And then turn the box upside down so that the inserted card is on the bottom and repeat the process.

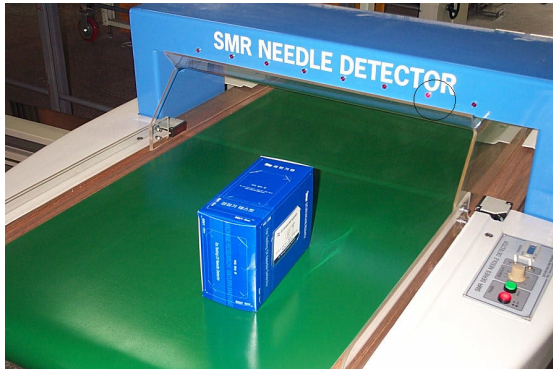

Lastly, insert the card into the side of the box and repeat the process once again.

If the detection lamp does not stop being lighted in the absence of the test equipment despite the execution of the process above, the problem is due to the improper installation site of the detector. Read the suggestions for choosing the installation site again and reinstall the detector at a proper site, and then execute the test again.

2) In the case of needleworks with metallic accessories
Even though the zippers and other accessories used for needleworks are made of non-ferric metals, the detector may still respond to them provided that their size is large enough and the detection sensitivity is high enough. As a result, if the needleworks that are to undergo detection process include any metallic accessories, adjust the detection sensitivity by using the following method.

First, set the volume of detection sensitivity at 10 and pass the test product through the detector. Repeat the detection process while gradually lowering the detection sensitivity until the detector does not respond to the metallic accessories. **Do not decrease the volume of the detection sensitivity under 3.** Then execute the detection process at this detection sensitivity over and over.

After that, execute the detection test by using the test box using the same method explained in Section a).

Note: If the detector still responds to the metallic accessories even after lowering the detection sensitivity substantially, it indicates that the accessories contain ferric substances.

Remove the accessories from the needleworks and execute the detection test. Otherwise, use specially gilded accessories that are not be detected.

10. How to Operate

- a) **Turn on** the detected materials return switch(4) and test mode switch(5)
- b) Turn on the power.
- c) Press the operation switch (For stable operation it takes 2~3 seconds after pressing the switch.)
- d) Start to operate the machine after lamp of the operation switch has been turned on.
- e) Place the product to be detected on the conveyor.
- f) if the product have any broken needle, the detecting lamp is lighted red and signal sound is heard and then the product is returned to the start position.
- g) The machine stop automatically after 5 minuets if there is no use.

11. Trouble shooting

- 1) In case there are strange noisy on the machine

Ⓐ In case bearing such as motor bearing, roller bearings and bearings for sustaining various shafts are broken.

→Refer to the parts list on the manual book and place an order to

the maker. And replace the broken bearings by the qualified person.

ⓑ Broken belts or lacking of tension

Qualified technician replace a new belt and adjust the tensions.

2) In case a detecting lamp is lighted without any metallic materials when only operation switch is turned on.

ⓐ In case a detecting sensitivity is too high.

→low the adjustment switch for the volume of detecting sensitivity.

But do not low it under 3.

ⓑ In case only one detecting lamp is continually lighted at regular intervals.

→Clean the outside or inside of conveyor belt with power switch must be turned off.

12. Maintenance

1) Cleaning the belt



After turning off the motor and the power switch



And pulling the plug from the socket.



polish the machine with a towel and a small amount of water or soaped water. Apply alcohol on severely filthy parts and scrub them softly.

When cleaning the whole conveyor belt



Turn on the power switch and turn on the operating switch. And lightly press a piece of cloth on the belt. It can be cleaned automatically.

The conveyor belt is easily made dirty. Keeping the belt clean can prevent its malfunction.

When signaling sounds are periodically heard from a certain place and the detection lamp is lit despite the fact that nothing is put in the detector, it may indicate that there are ferric alien substances in the conveyor belt. Turn off the power and clean the belt thoroughly by rotating the belt with your hand.

Caution: Moisture or soaped water on the surface of the belt may cause the belt to become unclean easily. Refrain from using irritative substances (thinner, benzene, acetone, for instance) and an excessive amount of water, for they can do damage to or deform the belt.

2) cleaning the machine

The machine must be cleaned with dry dustcloth at least once a week.

When the machine isn't used please cover the machine with fabric or cover.

13. Repair

-The way of adjusting the leaning of the belt

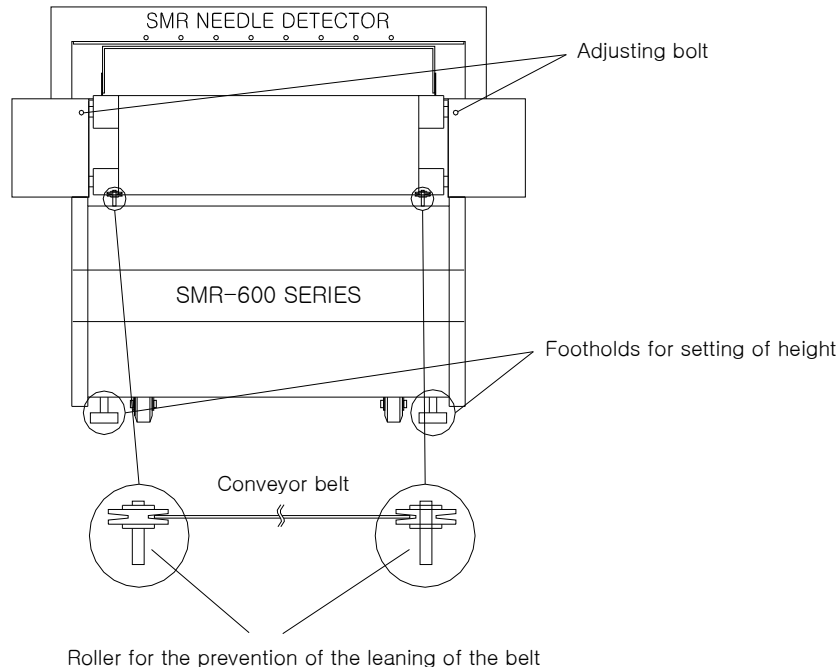

a) Using the bolt (6mm Allen key) for adjusting the leaning belt, loosen the conveyor belt.

b) Fasten the bolt very slowly with the belt inserted into the groove in the roller for the prevention of the leaning of the belt, to adjust the tension.

c) Operate the detector and idle the belt for about 10 minutes. If the belt does not get separated from the roller for the prevention of the leaning of the belt, the adjustment is finished.

d) If the belt leans to the right, fasten the adjustment bolt on the right slowly and unfasten the adjustment bolt on the left, to adjust the tension. If the belt idles without leaning, the adjustment is finished. If the belt leans to the left, use the same method above in the opposite manner; fasten the left adjustment bolt slowly and unfasten the right adjustment bolt.

14. Quality Guarantee

SMR CO. warrants this needle detector, SMR-600A with following terms and conditions below :

1. This warranty will be valid for a period of **one year** from the date of the original purchase in case of defect under normal use as instructed in user's manual.
2. This warranty will not extend to the following :
 - damage or defect caused by transportation, abuse, improper use of negligent use.
 - damage or defect caused by fire, earthquake, flood or other natural disasters.
 - damage or defect caused by alteration, conversion, modification or improper repair.

We charge for services after the guarantee period. Please be sure to keep this in mind.